



*Atlas Copco*



# Maximizing flexibility for small-scale LNG

Atlas Copco Gas and Process gives you the  
agility to compete — with reliability that  
boosts the bottom line.

**HANDLE THE PRESSURE**

# Flexibility, reliability and efficiency for small-scale LNG plants

As the demand for liquified natural gas (LNG) grows — both as a fuel source and for power generation — producers are increasingly looking toward small-scale LNG (SSLNG) plants to provide the output and flexibility they require.

At Atlas Copco Gas and Process, we have a full line of centrifugal compressors, screw compressors and turboexpanders to meet your most demanding process needs.

Over seven decades, Atlas Copco Gas and Process has continuously innovated to keep industries moving and producing. With more than five decades of experience with LNG and oil-free screw compressors, and more than 80 years working with cryogenic services, we are constantly adapting proven technologies for new applications and markets.

## SSLNG plants fuel many applications, including:

- Transportation hubs for long-haul vehicles and shipping fleets
- Remote commercial and residential heating networks
- Cost-effective, stand-alone power generation in remote locations
- Peak shaving plants
- Virtual pipeline systems that deliver energy to off-grid customers

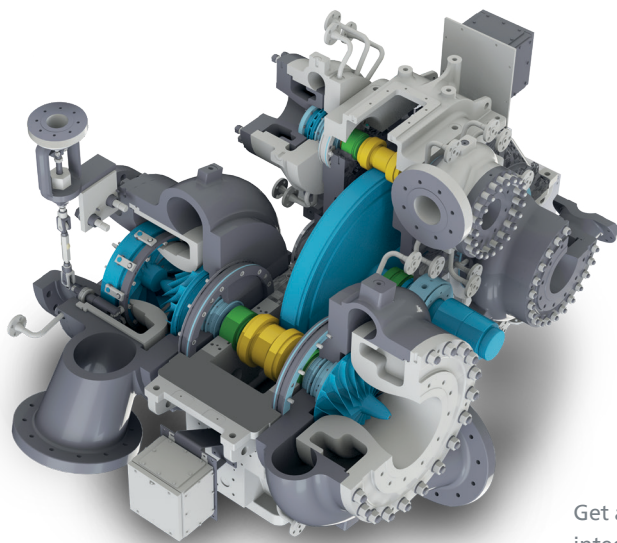

Get a technical edge with integral-gear technology

# Handle the Pressure with Atlas Copco Gas and Process

Groundbreaking integral-gear technology makes Atlas Copco Gas and Process compressors uniquely versatile.

With modular integral-gear designs that can lower CAPEX and engineering while simplifying long-term maintenance, our engineers have the expertise to then tailor solutions to meet your plant's exact needs and goals.

Over 70 years of experience have enabled us to develop robust, reliable and efficient solutions for our customers. Always at the forefront of the market, we have designed and produced over 8,000 compressors, expanders and companders.

Atlas Copco Gas and Process integral-gear technology offers customers the efficiency, flexibility and reliability they demand. Up to eight stages can run on a single gearbox, providing optimal process speeds with a minimal footprint. By incorporating technologies like variable inlet guide vanes (IGV) and diffuser guide vanes (DGV), we ensure your plant has the process flexibility to handle changing gas types and plant conditions.

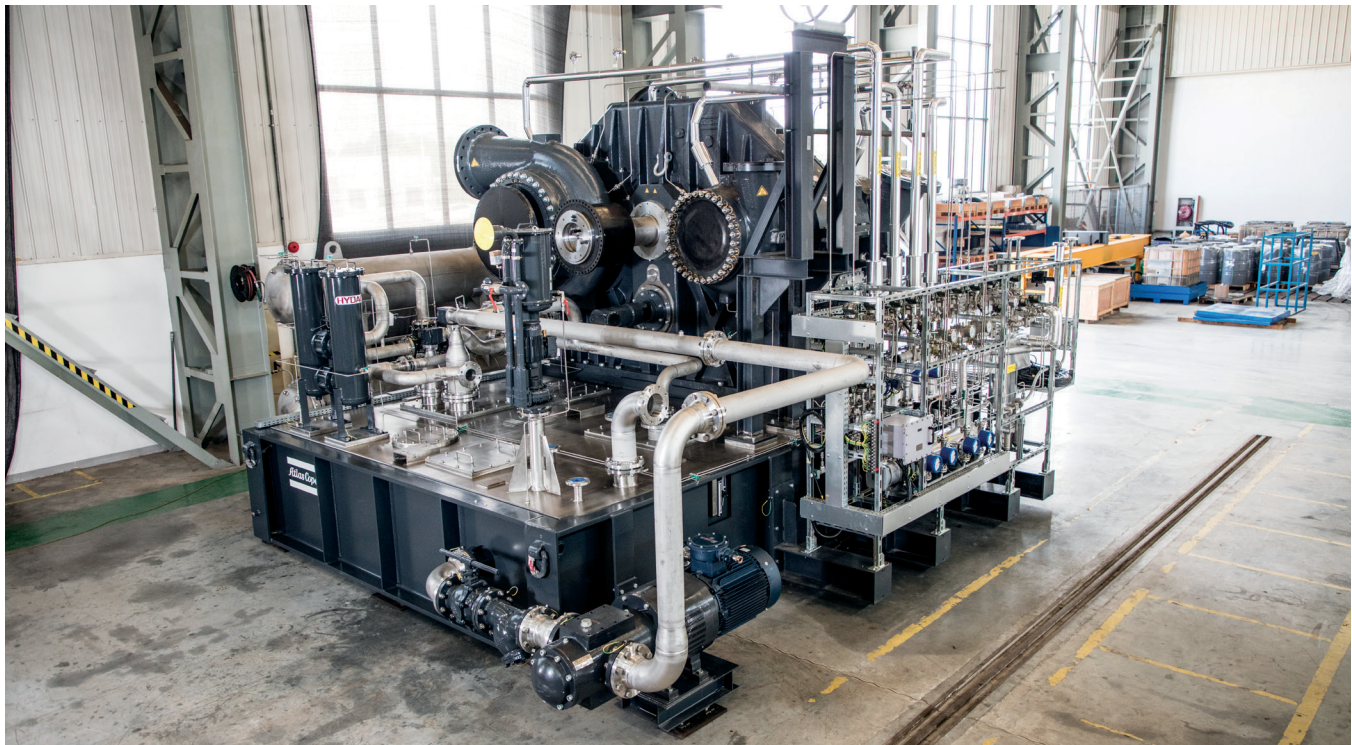

The world's first integrally geared 27 MW mixed-refrigeration compressor from Atlas Copco Gas and Process

# Find the right solution for your SSLNG plant

## Componders

An Atlas Copco Gas and Process original, the Componder merges compressor and expander functionality into a single machine that is ideal for onshore and smaller offshore liquefaction plants. Features include:

- A model of efficiency
- Space, energy and operational cost savings
- Increased LNG load
- Nitrogen or methane cycle
- Centrifugal technology for hydrocarbon or inert gas

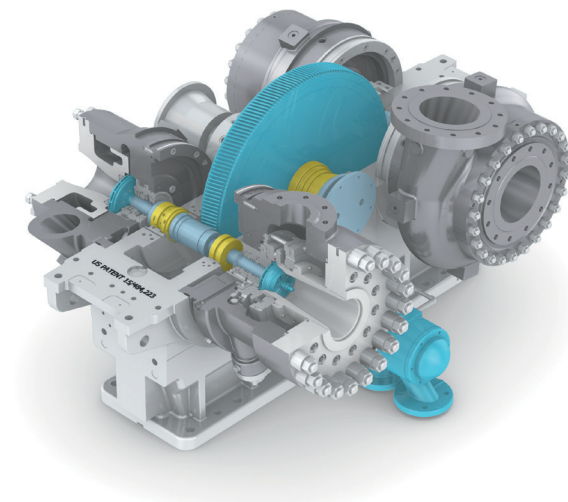
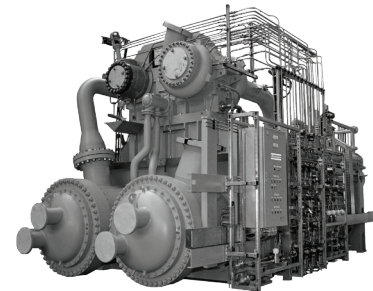

Componder Gearbox

## Nitrogen Brayton cycle with warm & cold expander

Used where demand is unstable and frequent plant startup and shutdown are required. Benefits include low CAPEX and increased flexibility.

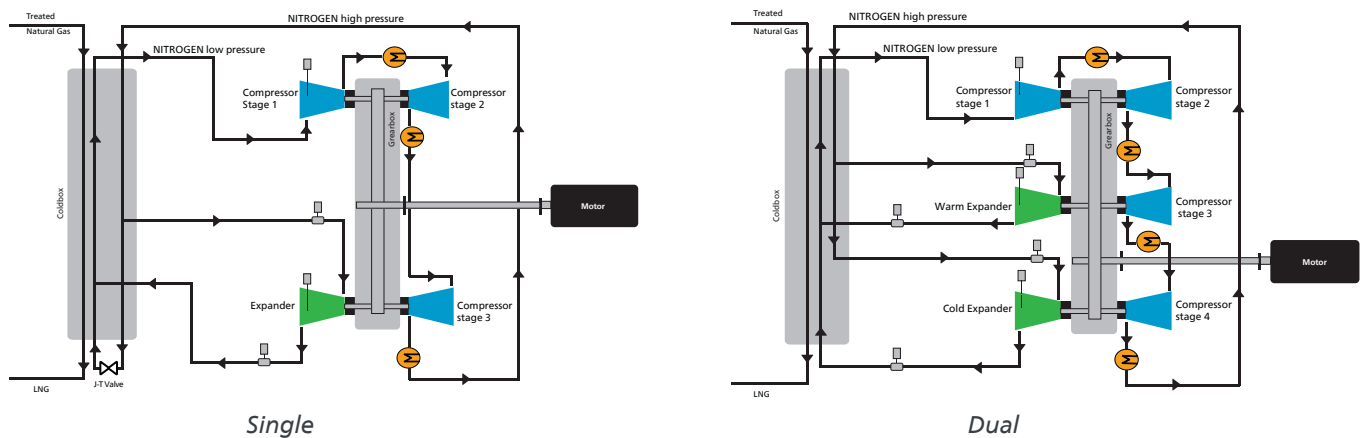

# Expanders

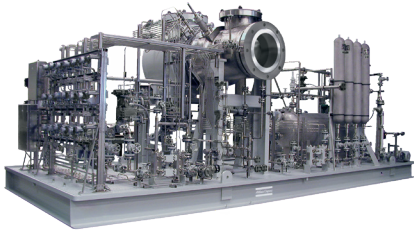

Our expanders aid liquefaction, regasification, processing and the recovery of valuable liquefied petroleum gas. Features include:

- Compact design
- Magnetic bearings that minimize wear
- Maximum flexibility that optimizes performance
- Nitrogen or methane cycle
- Magnetic or oil bearings

## Methane cycle

Used where high-pressure gas supply is available. Offers lowest CAPEX below 50,000 GPD (100,000 Nm<sup>3</sup>/day) plant size.

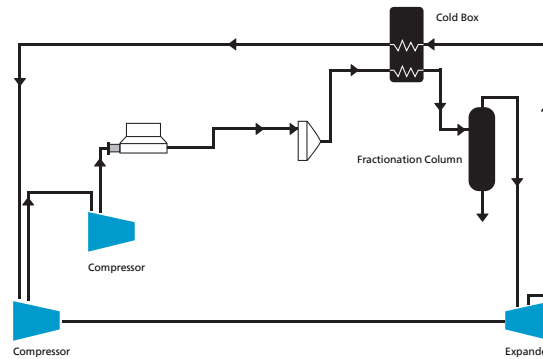

## Mixed-refrigerant compressors (MRC)

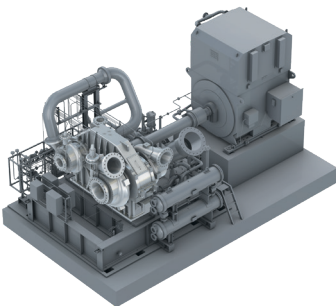

Atlas Copco Gas and Process mixed-refrigerant compressors use a mixed hydrocarbon refrigerant. Built with compact, skid-based modularity, they can minimize the necessary footprint while maximizing reliability and efficiency. Features include:

- Intercooling between independently controlled stages, which boosts efficiency
- IGVs and DGVs, which allow for precise control
- A single dry-gas seal, minimizing seal leakage
- Optional centrifugal technology
- Up to eight stages on a single gearbox

## Single mixed-refrigerant cycle (SMR)

Used where stable plant operation is required. Offers increased plant efficiency beyond 250,000 GPD (500,000 Nm<sup>3</sup>/day) plant size and a higher coefficient of performance.

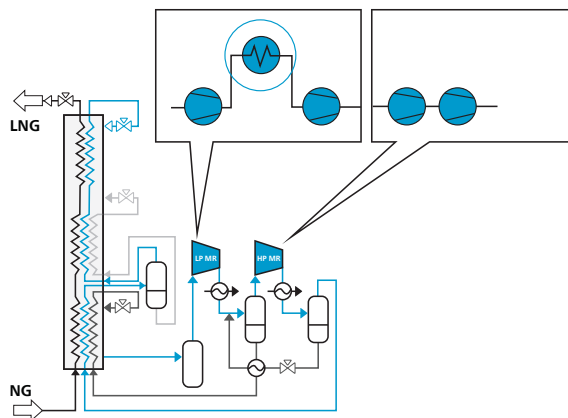

# Maximize efficiency at every step

When you work with Atlas Copco Gas and Process, we start with a standardized model to minimize CAPEX and engineering, and take a consultative approach to identify your optimal course of action.

We can fully customize your solution to meet your specs and goals while delivering first-class technical support and service that keep you in production.

- Robust reliability that minimizes downtime
- Compact machinery with a smaller footprint
- Significantly reduced operating costs compared to current technology
- Unique oil-free solutions that need less maintenance
- The flexibility to handle both rich and lean gas, even in extreme temperatures
- Complete solutions, from standard to fully customized

Small Scale	Applications	Nitrogen Cycle	MR Cycle	Methane Cycle
Type & Technology	Features			
Mixed-refrigeration Compressor (Centrifugal)	Custom designed to specification, IGV / DGV control, single skid / single lift design, high efficiency		✓	
Compander Nitrogen / Methane (Centrifugal / Compander)	Hydrocarbon, inert gas	✓		✓
(HD) Vapor Return Blower (Centrifugal)	Cryogenic, IGV or ITV control, parallel sequencing	✓	✓	✓
(LD) BOG Compressor (Centrifugal)	Cryogenic, IGV or ITV control, parallel sequencing, up to 2–5 stages of compression	✓	✓	✓
(LD) BOG Compressor (Oil-free Screw)	VFD control, up to 24 bar(a), with gas preheater, intercooler and aftercooler, compressor package designed for installation in hazardous area, low maintenance costs, up to 3 stages of compression	✓	✓	✓
(LD) BOG Compressor (Oil-injected Screw)	VFD control, up to 44 bar(a), completely packaged and wired with gas preheater, intercooler and aftercooler, compressor package designed for installation in hazardous area, up to 2 stages of compression	✓	✓	✓
Expander — Nitrogen / Methane (Magnetic or Oil Bearing)	Hydrocarbon, inert gas	✓		✓
Excess BOG Compressor (Centrifugal)	Custom designed to specification	✓	✓	✓
Regen Gas Compressor (Centrifugal)	Custom designed to specification	✓	✓	✓
Instrument Air Compressor (Centrifugal)	Custom designed to specification	✓	✓	✓

# A full range of solutions for any LNG process

Atlas Copco Gas and Process offers the flexibility you need in your small-scale LNG plant with fully customizable turbomachinery solutions.

Small-scale LNG Solutions														
Nm <sup>3</sup> /h Gas	872	1,745	2,617	8,723	12,500	17,446	21,807	31,250	41,667	74,204	148,408	445,223	742,039	
Nm <sup>3</sup> /d Gas	20,935	41,870	62,804	209,348	300,000	418,696	523,370	750,000	1,000,000	1,780,893	3,561,786	10,685,359	17,808,932	
gpd LNG	10,000	20,000	30,000	100,000	143,302	200,000	250,000	358,255	477,673	850,685	1,701,370	5,104,110	8,506,849	
t/h LNG	0.66	1.34	2.01	6.71	9.62									
tpd LNG	16	32	48	161	231	322	403	577	769	1,370	2,740	8,219	13,699	
tpa LNG	5,878	11,755	17,633	58,776	84,227	117,552	146,940	210,569	280,758	500,000	1,000,000	3,000,000	5,000,000	
mta LNG	0.006	0.012	0.018	0.059	0.084	0.118	0.147	0.211	0.281	0.5	1.0	3.0	5.0	
Mixed Refrig.	Compressor		[Blue shaded area]											
HC / CH <sub>4</sub> Cycle	Compressor		[Blue shaded area]											
	Expander		[Light blue shaded area]											
	Compander		[Teal shaded area]											
Nitrogen Single Cycle	Compressor		[Blue shaded area]											
	Expander		[Light blue shaded area]											
	Compander		[Teal shaded area]											
Nitrogen Dual Cycle	Compressor		[Blue shaded area]											
	Warm Expander		[Light blue shaded area]											
	Cold Expander		[Light blue shaded area]											
	Compander		[Teal shaded area]											



Atlas Copco Gas and Process  
Schlehenweg 15, 50999  
Cologne, Germany  
[atlascopco-gap.com](http://atlascopco-gap.com)

